



Embedded Software Research and Development in Korea

Heonshik Shin, Professor
School of Computer Science and Engineering
Seoul National University

August 18, 2003



Contents

- Introduction
- Embedded software industry in Korea
- R & D Projects for Embedded Software
- Research sectors
- Examples of embedded software
- Education of embedded software professionals
 - A case study
- Epilogue



Introduction

Prolog
Background
Goals of this talk



Prolog

- Why?
 - No ubiquitous No pervasive without Embedded
 - Human beings now in information age: Why not machines and devices?
- What?
 - Diverse applications: No universal solutions
 - Every device/machine needs its own 'mind'.
 - Every researcher/company/country has work to do.
- Real-time vs. Embedded
 - All embedded systems are real-time systems.
 - *cf.* rectangles vs. squares
 - In this talk, embedded ← real-time + embedded





Background

- All the next-generation products need to get smart and *high-tech*.
- Korean industry has never been a good player in the areas of software for legacy applications.
- Embedded software is a new world where no dominating, conspicuous winners exist.
- Now, we *can do* it!!!
- In addition, the government looks to the embedded software for the promising technology for the nation's future economy.
- The Ministry of Information and Communication enjoys "huge" funds for R&D of information and communication technologies.



Goals of this talk

- This talk will attempt to present the current status of embedded and real-time software R&D in Korea from various standpoints, emphasizing the following:
 - Embedded software industry
 - Research and development of embedded software
 - Embedded software professionals





Korea in the world

■ Electronics industry market shares (2002)

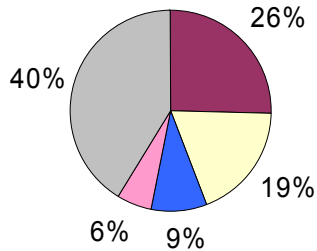

■ U.S. ■ Japan ■ China ■ Korea ■ Other countries

(Source : Yearbook of World Electronics Data 2002)



August 2003

Embedded Software KOREA

7



■ Top-class technologies

- Memory semiconductor
 - World No.1 (penetration rate: 25.4%)
- CDMA Mobile phone
 - World No.1 (penetration rate: 49.1%)
- TFT-LCD
 - World No.1 (penetration rate: 39%)



August 2003

Embedded Software KOREA

8

■ Mobile phone market shares

	Company	Sales to users Millions of units	Market shares (%)
1	Nokia	39.6	35
2	Motorola	16.6	14.7
3	Samsung	11.9	10.5
4	Ziemens	8.6	7.6
5	LG	5.0	4.5

(Source : Dataquest 2003)



August 2003

Embedded Software KOREA

9

■ Network infrastructure

- World No.1 broadband subscribers (7.3 millions, penetration rate 51%)
- World No.9 mobile subscribers (29 millions, penetration rate 62%)

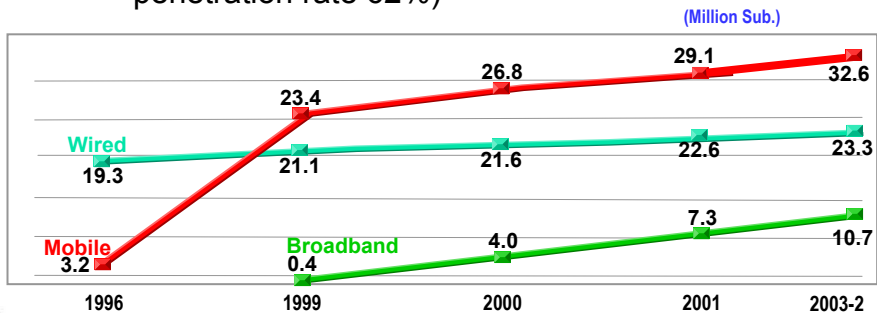

August 2003

Embedded Software KOREA

10





Embedded Software Industry in Korea

Overview

- Startup companies for embedded S/W
- Organizations for embedded S/W

Overview

■ SWOT analysis

<p>S (Strength)</p>  <ul style="list-style-type: none">- Good network infrastructure- Top-class technologies in consumer electronics- Agile adaptation to new technology	<p>W (Weakness)</p>  <ul style="list-style-type: none">- Brand image
<p>O (Opportunity)</p>  <ul style="list-style-type: none">- Emerging markets (e.g. China)- Competent startup companies	<p>T (Threat)</p>  <ul style="list-style-type: none">- Fierce competition- Small domestic markets

Relationships among vendors and developers

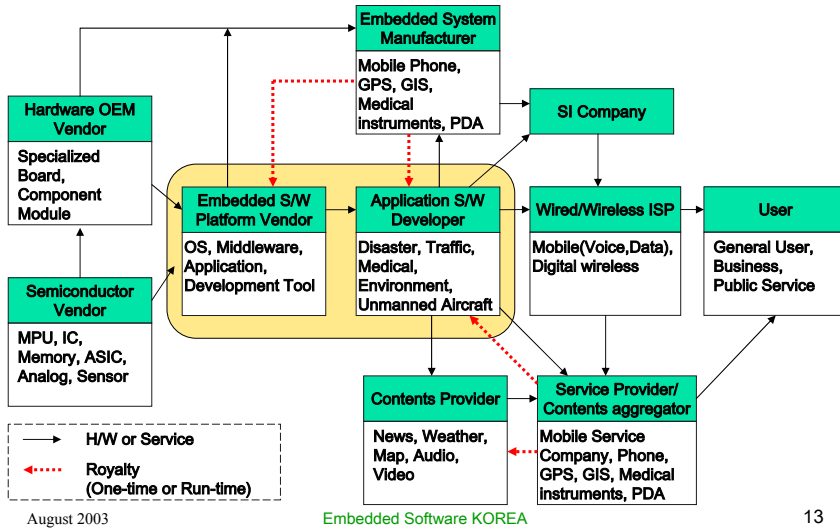

Market scale of domestic embedded S/W industry

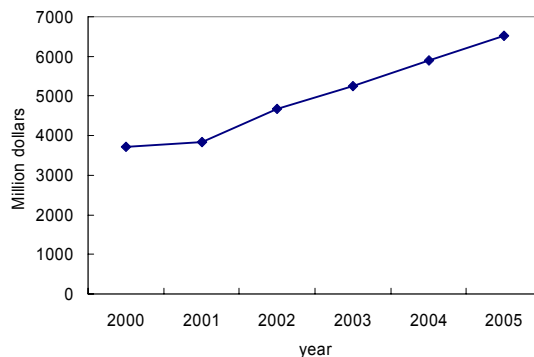

(Source : Gartner 2001)



■ Market shares of embedded S/W

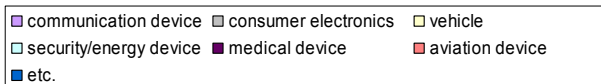
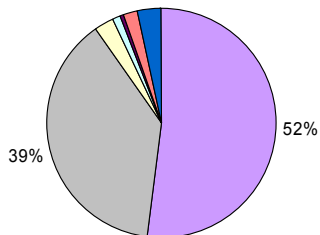

August 2003

Embedded Software KOREA

(Source : Gartner 2001)

15



Startup Companies for Embedded S/W

■ Total amount of sales

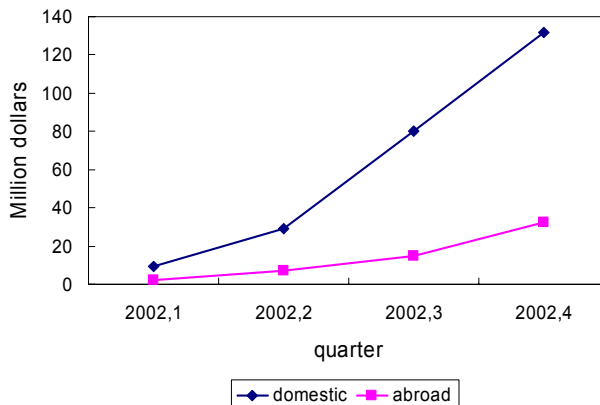

(Source : 2002 Embedded S/W industry trend survey, Korea IT Industry Promotion Agency)



August 2003

Embedded Software KOREA

16



■ Domestic embedded S/W market

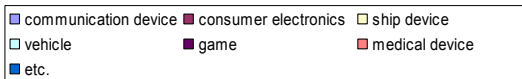
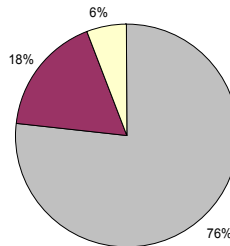
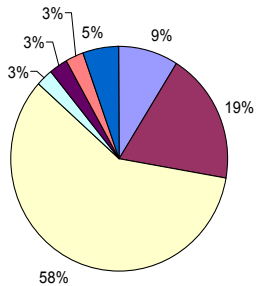

(Source : 2002 Embedded S/W industry trend survey, Korea IT Industry Promotion Agency)



August 2003

Embedded Software KOREA

17



■ Overseas embedded S/W market

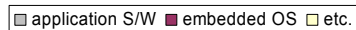
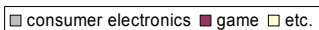
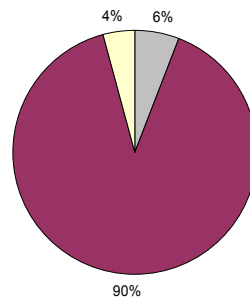
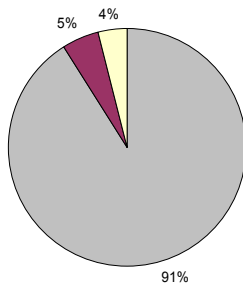

(Source : 2002 Embedded S/W industry trend survey, Korea IT Industry Promotion Agency)



August 2003

Embedded Software KOREA

18



■ Distribution of engineers

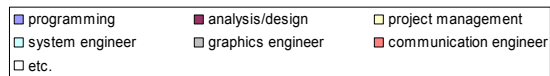
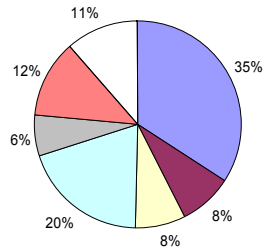

(Source : 2002 Embedded S/W industry trend survey, Korea IT Industry Promotion Agency)



August 2003

Embedded Software KOREA

19



Organizations for Embedded S/W

- Smart Home Standardization Forum (4 divisions)
 - Smart home system
 - Media electronics
 - Automation
 - Sensor and health care
- Embedded Linux Consortium (ELC) Korea
 - Standardize the platform for embedded Linux
- Wireless Internet Standardization Forum
 - Establish the standard for domestic wireless Internet platform (WIPI)



August 2003

Embedded Software KOREA

20



- Embedded software industry
 - Cooperate with other organizations for adapting standard embedded S/W technologies and developing embedded systems
- Government branches (Ministries)
 - Adapt the standard embedded S/W technologies to its own IT-related projects
- Digital Media City (City of Seoul)
 - Used as the test environment in which embedded systems are built and new services are integrated



R & D Projects for Embedded Software



Major projects
Plan for embedded software
industry promotion



Major Projects

Areas	Titles	Periods, budget (million USD)	Target equipments
Disaster prevention	National safety management information system	2003-2006 (43)	Integrated disaster warning terminals, AV system for disaster prevention
Environment	Remote automatic environmental monitoring system	2001-2005 (private sector)	TMS data logger, Telemetry system
Medicine	Human Tech21	2002-2010 (186)	Smart watch, Remote home health terminal
Transportation	ITS 21	2001-2010 (6,385)	On-board equipment(OBE), Road side equipment(RSE), Vehicle detection system(VDS), Lane control system(LCS)
Aviation	New Frontier 21 (unmanned aircraft)	2002-2012 (77)	Navigation, Air control, Engine control systems
LBS	LBS industry promotion plan	2003-2005 (64)	Location positioning system, LBS terminals
Metropolitan	Digital media city (SmarTown)	2002-2010 (1,308)	Location information systems Intelligent street lights



■ Project Case 1: Internet appliances

(November 2000 ~ December 2002)

- Objectives
 - To develop the *control middleware* for automated configuration, easy management and interoperability among devices on wired/wireless home networks
 - To develop the *multimedia middleware* for interactive media streaming service
 - To develop the Universal Information Appliance(UIA) for wireless home network, integrated control, and management of home information
- 20 cooperative research organizations
 - Motorola, Samsung, LG, Dasan, JTeL, etc.





■ Project Case 2: Embedded software platform for SmartTown (January 2003 ~ December 2007)

● Objectives

- To develop core embedded software technologies necessary for future digital city, SmartTown, which provides an integrated digital life at any time, at anywhere, and with any device

● Main Issues

- Developing embedded S/W platform technologies
 - Embedded OS for ubiquitous computing, real-time object handling, ubiquitous networking, application framework, and development toolkit
- Building test environments for SmartTown services



August 2003

Embedded Software KOREA

25

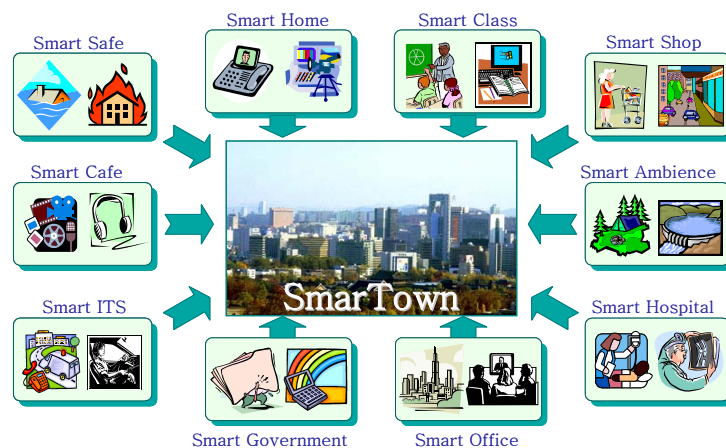

August 2003

Embedded Software KOREA

26

Plan for Embedded Software Industry Promotion – Ministry of Info. and Comm.

■ Vision

- The first country with a dream of “Embedded, Everywhere” fulfilled
- One of the countries with the most advanced embedded software technology by the year 2007

■ Execution strategy

- Move from catch-up strategy to leading strategy
 - Catch-up stage: assembly and manufacturing
 - Leading stage: original technology and international standards
- Develop world-best products by adopting domestic embedded software for our competitive products, such as wired/wireless communication equipments and home appliances
- Implement the “digital life” as early as possible by constructing a model *SmartTown* based on domestic embedded software



August 2003

Embedded Software KOREA

27

Phased plan for deploying model services

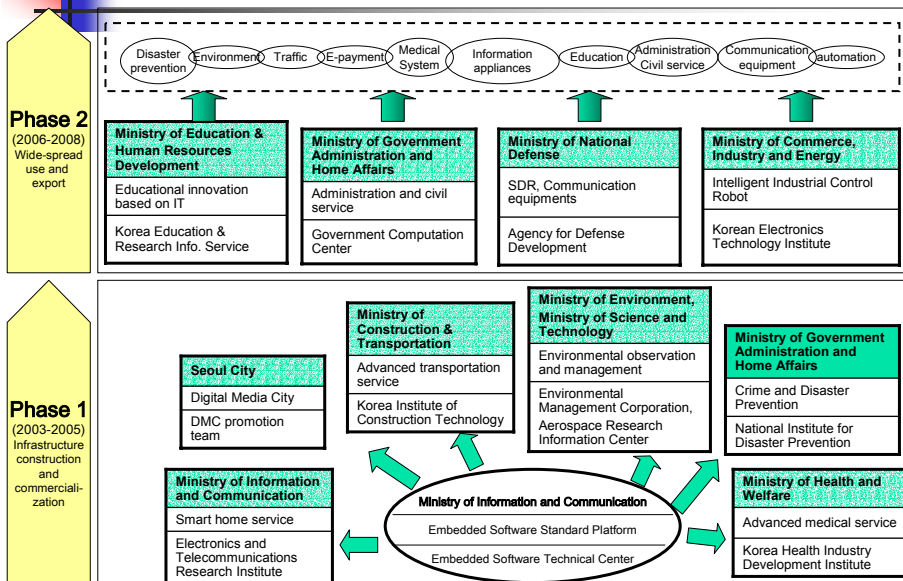

August 2003

Embedded Software KOREA

28

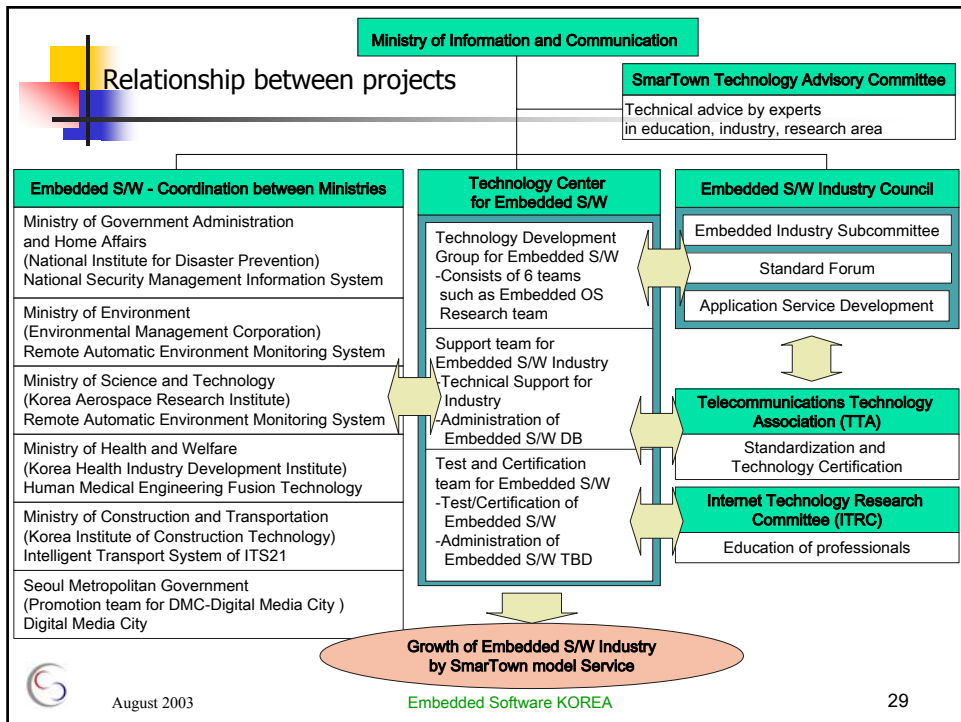

-
- ## ■ Approaches
- Development of core technology and standardization
 - Phase 1 (2003 - 2005)
 - Establish the standard for embedded Linux API-based platform
 - Develop the implementation reference model
 - Phase 2 (2006 - 2007)
 - Apply the embedded software platform to diversified embedded systems
 - Realization of model services
 - Example: Intelligent traffic information service using an embedded software platform
 - Education of embedded software professionals
- August 2003

Embedded Software KOREA

30

Example: Intelligent traffic information service using an embedded software platform

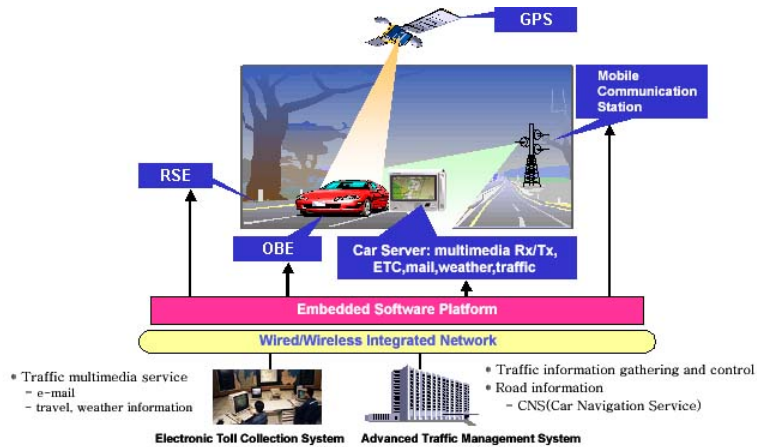

August 2003

Embedded Software KOREA

31

Research Sectors

Academia
ETRI
KETI
Samsung / LG
Defense



Major Research Institutions

- Academic institutions
- ETRI (Electronics and Telecommunication Research Institute)
 - Embedded Software Technology Center
- KETI (Korea Electronics Technology Institute)
 - Ubiquitous Computing Research Center
 - Center for Post-PC Industry Support
- Samsung Electronics
- LG Electronics
- ADD (Agency for Defense Development)
 - Guided missiles
 - Advanced weaponry



Academia – Some examples

- Development of kernels and UPnP for device control using PLC communications
 - Embedded middleware called MDS
 - RTOS Lab. (Prof. S. Hong), Seoul National University (SNU)
 - <http://redwood.snu.ac.kr>
- Embedded real-time OS and middleware for consumer electronics
 - Development of integrated environment for the design and implementation of embedded S/W
 - RTOS Lab. (Prof. S. Hong), SNU
- PeaCE: A HW/SW codesign environment for multimedia embedded systems
 - Codesign problems on the architecture selection and mapping, software performance estimation, and cosimulation
 - CAP Lab. (Prof. S. Ha), SNU
 - <http://peace.snu.ac.kr>





- Development of high-speed HW/SW SoC co-simulation tool and optimization of NAT performance
 - CS Lab. (Prof. H. Shin and Prof. N. Chang), SNU
 - <http://cselab.snu.ac.kr>
- Low-power software technology for mobile real-time systems
 - ARCHI&NET Lab. (Prof. S. Min), SNU
 - <http://archi.snu.ac.kr>
- Development of Java JIT compiler for embedded system
 - MASS Lab. (Prof. S. Moon), SNU
 - <http://altair.snu.ac.kr>



- Development of next-generation digital convergence platform
 - Focusing on the development of agent-enabled mobile terminal using component-based S/W technology
 - CS Lab. (Prof. H. Shin and N. Chang), SNU
 - <http://cselab.snu.ac.kr>
- Establishment of software development environment for mobile terminals
 - Multimedia Systems Lab. (Prof. W. Sung), SNU
 - <http://mpeg.snu.ac.kr>





- Sensor network platforms and ad-hoc network protocol
 - Real-time and Embedded Systems Lab. (Prof. D. Lee), Information and Communication University
 - <http://vega.icu.ac.kr/~rts>
- Software environment for rapid ASIP prototyping
 - Development of ASIP (Application Specific Instruction-set Processors) prototyping tool
 - SO&R Lab. (Prof. Y. Paek), SNU
 - <http://compiler.snu.ac.kr>



- Representative research centers
 - ESRC (Embedded Systems Research Center)
 - Seoul National University
 - <http://esrc.snu.ac.kr>
 - Objectives
 - Develop strategic SoC
 - Develop embedded software
 - Educate high-quality professionals for embedded system design
 - Establish databases for embedded system design
 - SWRC (SoftWare Research Center)
 - Konkuk University
 - Cooperating with LG-CNS
 - Objectives
 - Develop embedded Linux platform
 - Multimedia streaming
 - Robot control
 - Monitoring





Embedded S/W Technology Center (ESTC)

- Supported by Ministry of Information and Comm.
- <http://www.etri.re.kr/english/comso/>
- Objectives
 - To develop efficient national information infrastructures
 - To enhance international competitiveness
 - To transfer technology to private/public corporations
- Research areas
 - Home server
 - Real-time OS and middleware
 - Portable client platform.
- Future plans
 - Development of embedded software standard platform technology (2003 ~2005)
 - Development of post-PC technology (2002 ~ 2004)
- Research staff: 80



August 2003

Embedded Software KOREA

39



Home Server and Digital Home

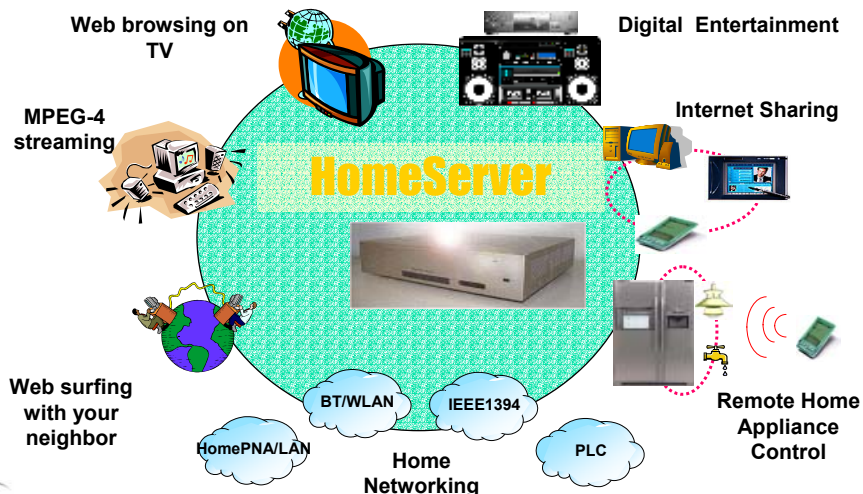

August 2003

Embedded Software KOREA

40



- Home multimedia entertainments
 - IP VoD streaming service
 - DVD
- Home Internet entertainments
 - Platform independent Java-based Web browser
 - Platform independent Java-based eBook reader
- Home security
 - Remote control of home appliances
 - HAVi-based camera and LonWorks-based magnetic sensor

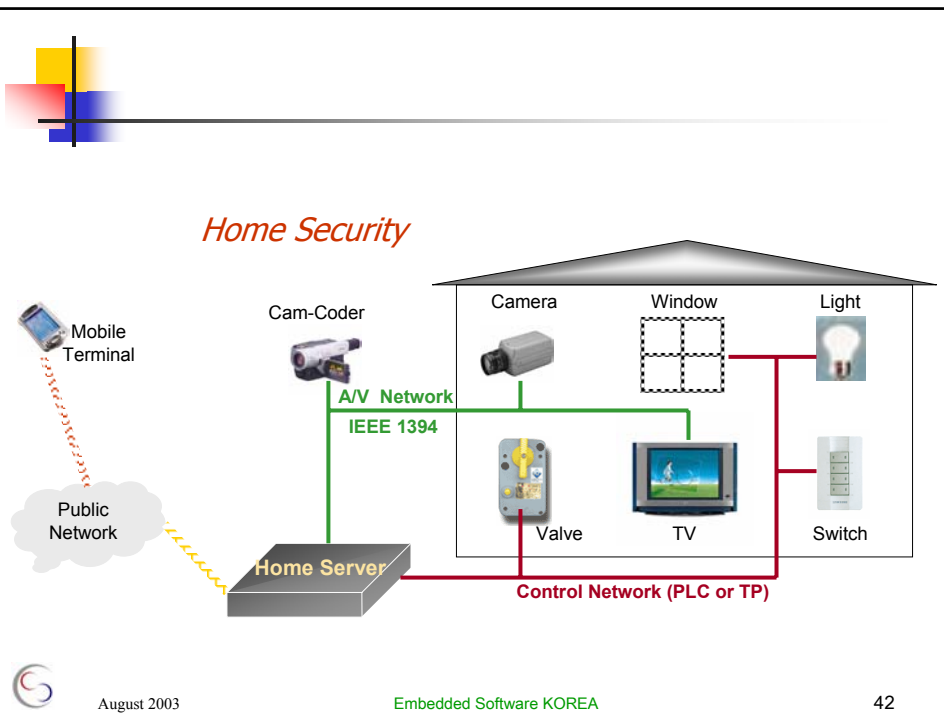



Korea Electronics Technology Institute (KETI)

- Supported by Ministry of Commerce, Industry and Energy
- <http://www.keti.re.kr/>
- Ubiquitous Computing Research Center
 - Establish Center for PostPC Industry Support
 - Develop devices and equipments for wireless networks and information appliances in cooperation with industry and academia
 - embedded Web server
 - Station-on-a-Chip chipset for next generation home station
 - Embedded OS and core software modules for mobile terminals
 - Java-based embedded Internet browser



- Center for PostPC Industry Support
 - For limited period: July 2001 ~ June 2006
 - Objectives
 - To provide environment for development of post-PC technologies
 - Validation of post PC products
 - Education of professionals for post PC technologies
 - Promotion of cooperation between companies
 - Budget : 4.6 million dollars





Samsung Electronics

- Embedded OS licenses or solutions
 - VxWorks, pSOS, embedded Linux
- Development of a smart phone SCH-i600 and home appliances
 - In cooperation with Microsoft
- Development of S3C2410 board based on ARM 9 Core
 - Standard evaluation board for the embedded system at Samsung
 - Development of embedded Linux for S3C2410 board
 - In cooperation with Mizi Research, Inc.
- <http://www.samsung.com/>



August 2003

Embedded Software KOREA

45



LG Electronics

- Development of IA devices
 - Refrigerator, laundry machine, and electronic oven which are capable of accessing the internet
- Plan
 - Development of the residential gateway based on Linux
- <http://www.lge.com/>

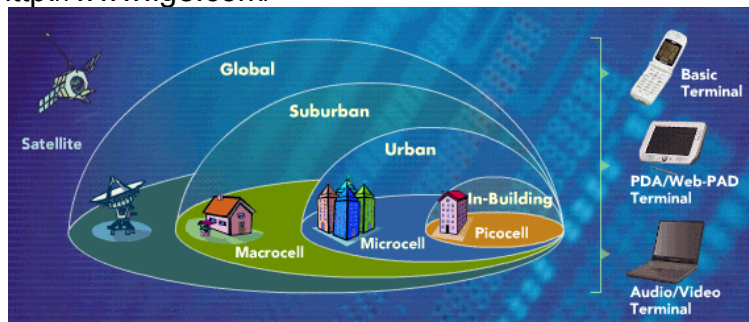

August 2003

Embedded Software KOREA

46



Examples of Embedded System Software

KELIX
Velos
Qplus/Esto
Tynux



KELIX

- Developed by Konkuk University (Prof. Moon H. Kim)
- Key features
 - Disk operation is eliminated
 - The execution-in-place (XIP) is provided to save memory spaces
 - Functions to construct main memory file systems are embedded
 - Small X-window system is provided
 - TMOSM/Linux is loaded on top of KELIX
- TMOSM/Linux - Real-time middleware
 - Deadline-driven real-time scheduling
 - TMO (Time-triggered Message-triggered Object) model support
 - 10 msec clock resolution
 - POSIX.1b support
 - Distributed IPC subsystem and activation



- Structure of the linux-based real-time operating system

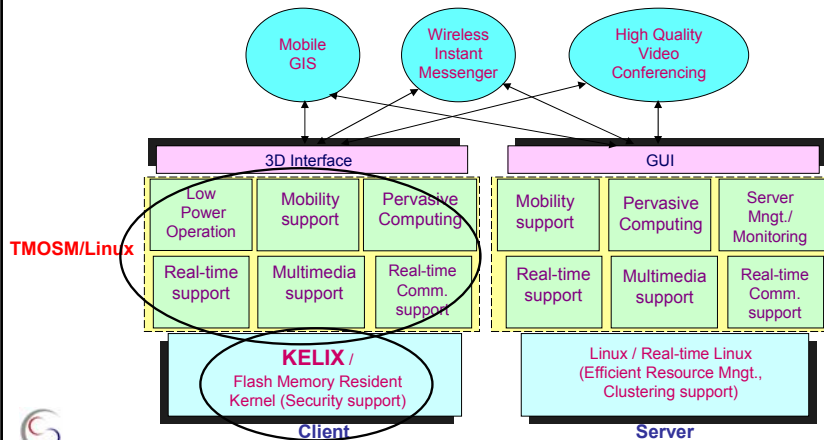

August 2003

Embedded Software KOREA

49

Velos

- Velos - Velocity of Light OS
 - Real-time operating system for embedded applications
- Developed by RTOS Lab. (Prof. Seongsoo Hong), Seoul National University
- Key features
 - Library kernel
 - POSIX 1003.13 PSE51 minimal real-time system profile support
 - Dynamic application loading
 - Real-time scheduling
 - TCP/IP network protocol stack – Linux
 - Window system – micro windows
 - JAVA support – KVM
- Product: iFeel PDA, Web Camera



August 2003

Embedded Software KOREA

50

Architecture

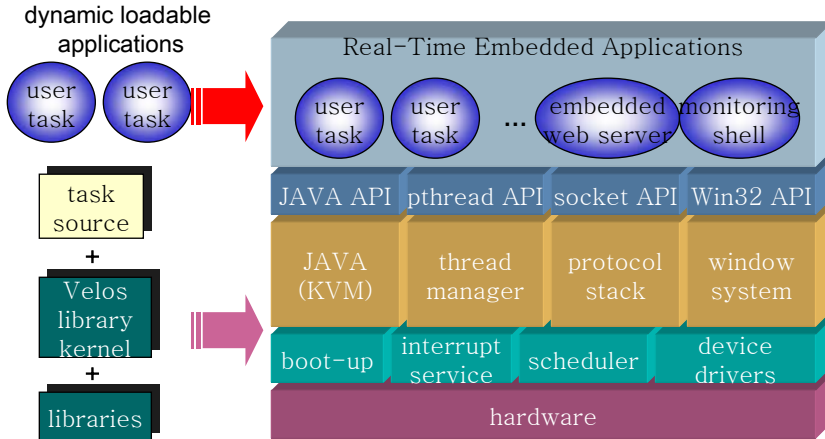

August 2003

Embedded Software KOREA

51

Product: Web Camera

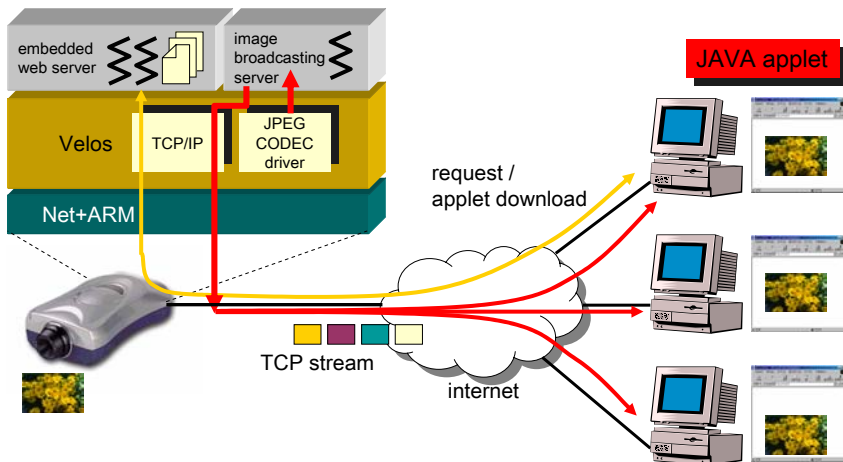

August 2003

Embedded Software KOREA

52

Qplus/Esto

- *Embedded Linux and development toolkit*
- Easy to develop embedded Linux applications with Qplus/Esto
 - Qplus Embedded Linux
 - Target Builder: OS configuration and Embedding Tool
 - Esto: Embedded Software Toolkit

Target Builder

Power Estimator

Project, Editor, and Output View in IDE

Breakpoint and Tracepoint Debugger

August 2003

Embedded Software KOREA

53

Architecture

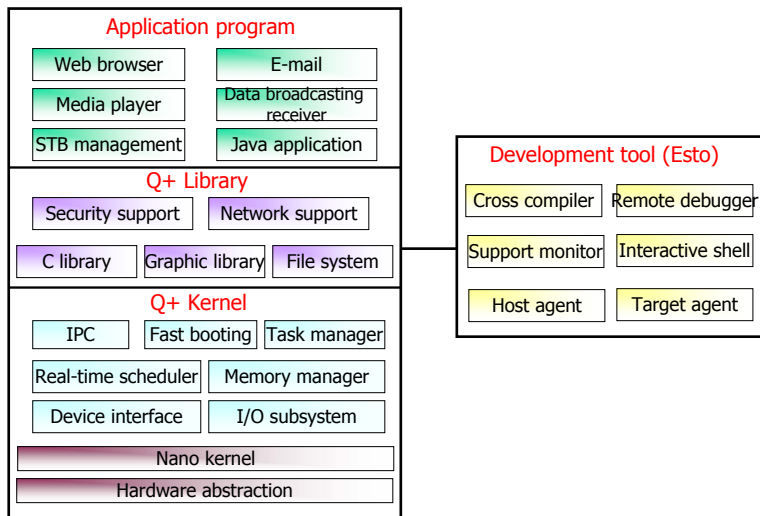



Qplus : Embedded Linux

- Qplus
 - Embedded Linux Solution for Digital Devices
- Qplus components
 - Linux Kernel 2.4.x with Preemptive Patch Applied
 - GUI Libraries: TinyX/GTK, QT/Embedded, ...
 - System Applications: Busybox, Tinylogin, Boa, ...
 - Multimedia Applications: MPEG1-2-4, DVD, MP3 players ...
 - Java Applications : Web Brower, eBook
- Target Builder
 - OS configuration & embedding tool



August 2003

Embedded Software KOREA

55



■ Kernel

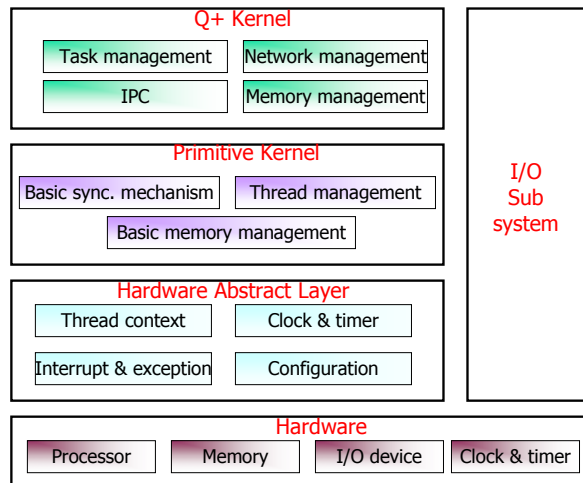

August 2003

Embedded Software KOREA

56



- *Easy-to-Use, User-Friendly IDE for Qplus*
- Runs on both Linux and Windows with the same look and feel



August 2003



Embedded Software KOREA

57



■ Esto's *Power Estimator*

- Quickly find where in your program consumes much power
 - Power is important resource in embedded system
 - Easy to develop power-saving program

Assembly-level Power

Statement-level Power

Function-level Power

FUNCTION	ENERGY	GAUGE	INDEX
main	0.330801	###	00000
gccmain	0.070715	=====	00001
time_tick	0.159527	#	00004
timeout	0.012817	=	00005
printf	0.020085	==	00006
vprintf	1.932361	\$	00007
deleteime	0.067717	=====	00052
timeout	1.240035	\$	00053
deleteime	0.067717	=====	00082
timeout	0.012817	=	00083
printf	1.272718	\$	00084
deleteime	0.067717	=====	00112
timeout	1.240035	\$	00113
deleteime	0.067717	=====	00142
timeout	1.240035	\$	00143
deleteime	0.070047	=====	00172



August 2003

Embedded Software KOREA

58



■ Esto's *Non-stop Debugging*

- Debug time-sensitive applications with our Non-stop Debugging solution



Time-sensitive Application

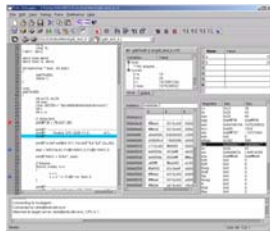

Stopping at Breakpoint

- Behave abnormally
- Wanted event doesn't occur

Tracepoint and Replay

- Add tracepoints and specify what information to collect
- Just Run!
- Doesn't stop at tracepoint
- Application runs at normal speed
- Replay application to inspect collected information



August 2003

Embedded Software KOREA

59



■ Other Features of Esto

- Qt-based GUI
- Project manager
- Source browser
- C/C++ cross tool-chain
- Multi-thread Debugging
 - More reliable and easy
 - Thread Window makes it easy to control and grasp many threads
- Remote Tracer
 - Shows execution of all process's in target graphically
- Remote Monitor
 - Shows status of resources such as process, memory, target system information, etc.
- Easily extensible architecture through Host Agent and Target Agent



August 2003

Embedded Software KOREA

60



- International cooperation

- ETRI and RedHat cooperatively developed Qplus based on RedHat's embedded software solutions and standards
- Academic Co-operations
 - University of Michigan
 - University of Pennsylvania
 - UC Irvine



Tynux

- Introduction

- Developed by PalmPalm Technology Inc.
- Integrates software solutions for
 - Smartphones, PDA, Webpad, E-book
 - Web screen phones and internet phones
- Main components
 - Kernel
 - Middleware
 - SDK
 - Applications



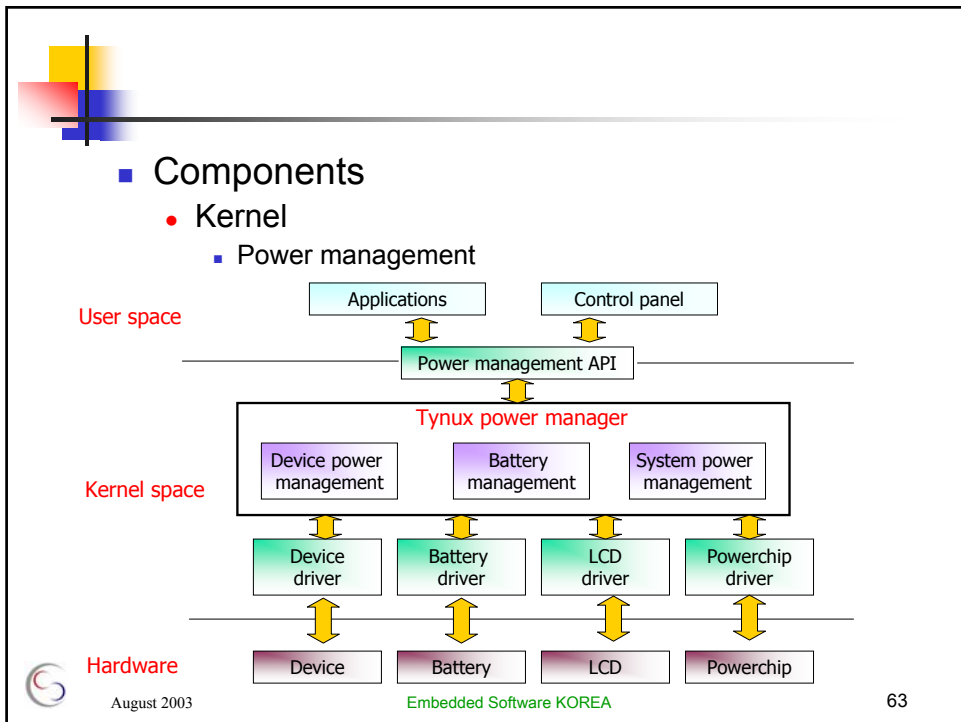

- Components (cont'd)
 - Kernel
 - Memory management
 - Efficient sharing and reuse of memory resources
 - Efficient reaction to memory shortage problems
 - XIP (eXecute-In-Place)
 - Direct loading from the Flash file system without being loaded onto the main DRAM memory
 - Reduce overall memory requirements
 - Support for a variety of devices
 - CCD camera, IEEE 1394, USB, Bluetooth, IrDA, Wireless LAN





■ Components (cont'd)

- Middleware
 - Various GUI environments
 - QT/E, Micro-X, Tiny-X, Microwindows Nano-X and GtkFB
 - Security
 - Secure web transport by supporting SSI and TLS
 - Library optimization
- SDK
 - Integrated Development Environment (IDE)
 - Tynux emulator



August 2003

Embedded Software KOREA

65



■ TB (Tynux Box) series

- Development toolkits for embedded Linux
 - Hardware reference board and schematics
 - Source and binary codes of Linux
 - Application programs and libraries
 - Cross development tools



TB-I



TB-II



TB-X



August 2003

Embedded Software KOREA

66



Adoption of Embedded Linux in Korea

Embedded systems	Adopters (companies)	Embedded Linux
PDA	SK Telecom	Embedded Linux by G.Mate
Measurement Instruments	SoCmaster of Huins, Inc.	Linux OS embedded in the core of ARM9 processor
Dedicated terminals	TelQoS	Winy Linux by Mococo
Home gateway	Samsung	Qplus by ETRI
Chip	Adchips	Embedded Linux 2.4.6 is loaded in EISC (Extended Instruction Core).
Robot	Robocom	Winy Linux by Mococo



August 2003

Embedded Software KOREA

67



Education of Embedded Software Professionals – A Case Study

Project overview
Action plan
Human resources
Mission
Target applications



Project Overview

- SNU Institute of Computer Technology (ICT)
- Objectives
 - To educate skilled professionals for embedded system software design and implementation
 - To develop related courseware
 - To establish an OJT center at ICT
 - SYSDEC (SYStem Design Education Center)
- Project period
 - 2003. 1 ~ 2007. 12
- Budget
 - 3.4 million dollars



August 2003

Embedded Software KOREA

69



Action Plan

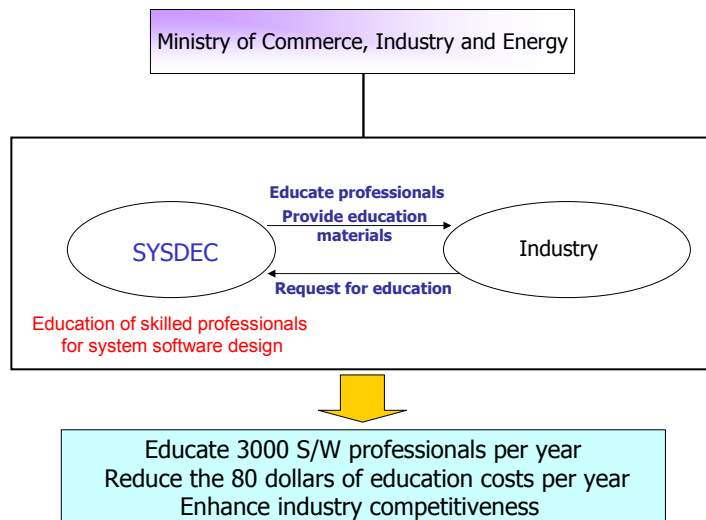

August 2003

Embedded Software KOREA

70



Human Resources (mobile terminals)

- Manpower for mobile terminals

Company	Number of employees	Number of R&D employees
Samsung	4,200	1,400
LG	1,800	1,300
Pantac & Curitel	2,350	900
Sewon	590	110



Mission

- Establish an education and training organization, SYSDEC
- Develop comprehensive courseware related to embedded/real-time software development
- Educate professionals on embedded/real-time software
- Provide OJT with system development tools and resources
- Cooperate with academic institutions
- Provide continuing education on new technologies for industry





Target Applications

- Mobile terminals (2003)
 - Embedded distributed programming
 - Windows CE.Net overview
 - Embedded RTOS
 - H/W and S/W for mobile phones
 - ARM programming for mobile phones
 - Mobile GUI based on Windows CE
- Post-pc devices (2004)
 - Implementation of CDMA technology
 - Linux programming
 - S/W optimization techniques for ARM processor
 - Mobile Java programming
 - T1 OMAP, C5x DSP programming



- Communication and networking (2005)
 - Xscale programming
 - Embedded DBMS
 - Flash memory S/W technology
 - Messaging system technology
 - Wireless internet
 - Protocol implementation
- Consumer electronics (2006)
 - Middleware for home networking
 - Video streaming
 - Display system
 - Embedded Linux





- wearable computing (2007)
 - Low-power software design
 - Sensor network
 - Testing and debugging for embedded S/W



Epilog

- Industrial products need to be intelligent to survive.
- At the center of this notion stands embedded software.
- We have the consensus that embedded software is one of the key technologies for the nation's future economy.
- Korean industry, academia, research centers and government are doing their best to lead the way, devoting much of their resource to promoting the embedded software research and development.

10 years later

Now, embedded_ware?

Yes, embodied everywhere!!





Thank you !

Tack så mycket !